

A REFLECTOMETER FOR H-F BANDⁱ

O. Norgorden

September 15, 1949

CLASSIFICATION CANCELLED OR CHANGED TO Unclassified
BY AUTHORITY OF NRL ltr 2028-215/50 DATED 2/16/50

Approved by:

Mr. R. B. Meyer, Head, Communication Branch

Mr. L. A. Gebhard, Superintendent, Radio Division II

NAVAL RESEARCH LABORATORY

Captain F R Purth, USN, Director

WASHINGTON, DC

**APPROVED FOR PUBLIC RESEASE
DISTRIBUTION UNLIMITED**

SECURITY

This document contains information affecting the national defense of the United States within the meaning of the Espionage Laws, Title 18 U.S.C., Sections 793 and 794. The transmission or the revelation of its contents in any manner to an unauthorized person is prohibited by law.

Reproduction of this document in any for by other than activities of the National Military Establishment and the Atomic energy Commission is not authorized unless specifically approved by the Secretary of the Navy.

AD-A953 594

DISTRIBUTION

CMO

| | |
|------------------|---|
| Attn: Code 413 | 1 |
| Attn: Code 413-C | 1 |
| Attn: Code 413-D | 1 |

OMR

| | |
|----------------|---|
| Attn: Code 470 | 2 |
|----------------|---|

BuShipps

| | |
|----------------|---|
| Attn: Code 911 | 7 |
| Attn: Code 833 | 1 |
| Attn: Code 980 | 1 |
| Attn: Code 981 | 1 |

BuOrd

| | |
|-----------------|---|
| Attn: Code R34Y | 1 |
|-----------------|---|

CO., OMR, Boston

1

DO., USNOTS

| | |
|--------------------|---|
| Attn: Reports Unit | 2 |
|--------------------|---|

Dir., USMEL

2

Supt., USMPGS

2

CO., NADS, Aeronautical Electronics & Electrical Laboratory

| | |
|----------------------|---|
| Attn: Dr. E. Krutter | 1 |
|----------------------|---|

| | |
|--------------------|---|
| Attn: Mr. E Steele | 1 |
|--------------------|---|

| | |
|---------------------------|---|
| Attn: Mr. E. R. Schlieben | 1 |
|---------------------------|---|

CDR., NATC

| | |
|--------------------------|---|
| Attn: Mr. K.S. Marquardt | 1 |
|--------------------------|---|

CO., SCEL

| | |
|---------------------------|---|
| Attn: Dir. of Engineering | 2 |
|---------------------------|---|

ComOpDevFor

1

CO., USNUSL

1

OCSigO

| | |
|------------------------|---|
| Attn: Mr. J.J. Koliher | 1 |
|------------------------|---|

| | |
|----------------------|---|
| Attn: Mr. A.R. Beach | 1 |
|----------------------|---|

| | |
|--------------------------------------|---|
| Attn: Ch. Eng. & TGech. Div. SIGTM-S | 1 |
|--------------------------------------|---|

DISTRIBUTION (Cont.)

| | |
|--|---|
| Ch. Of Staff, USAF | |
| Attn: Mr. Joseph Reichbrod | 1 |
| Dir., ESL | |
| Attn: Mr. O.C. Woodyard | 1 |
| Attn: Mr. Leonard Moore | 1 |
| CG. AMC, Wright-Patterson Air Force Base | |
| Attn: Major T.J. Gibbons (MCREEO) | 1 |
| Attn: Mr. R.E. Kester (MCREER) | 1 |
| Attn: A.L. Bell (MCREER) | 1 |
| Attn: Mr. George Rappaport (MCREER) | 1 |
| Attn: Major J.S. Lambert (MCREEP) | 1 |
| CO., Air Force Cambridge Research Laboratory | |
| Attn: Dr. R.C. Spencer | 1 |
| Attn: Mr. R.M. Barrett | 1 |
| Attn: ERRS | 1 |
| CO., Watson Laboratories, AMC, Red Bank | |
| Attn: ENS | 1 |
| BAGR., CD, Wright-Patterson AFB | |
| Attn: CADO-D1 | 1 |
| RDB | |
| Attn: Library | 3 |
| Attn: Navy Secretary | 1 |
| Attn: Committee on electronics | 3 |
| Attn: Chairman, Radiation Systems Panel | 1 |
| Namal Res. Sec., Science Div. | |
| Attn: Mr. J.H. Heald | 2 |

CONTENTS

| | |
|----------------------|---|
| Contents | |
| ABSTRACT | v |
| PROBLEM STATUS | v |
| AUTHORIZATION | v |
| INTRODUCTION | 1 |
| THEORY | 2 |
| REFLECTOMETER DESIGN | 6 |
| APPLICATION | 7 |

ABSTRACT

The general principles of reflectometer or directional-coupler design at the ultra-high frequencies have been applied to the lower frequencies (2- to 30-Mc band). Theoretical design equations, given for an approximate equivalent circuit of the reflectometer, show that the circuit parameters are independent of the frequency. The sensitivity of the device is approximately proportional to the frequency. Design constants are given for a reflectometer designed for the 4- to 15-Mc band but which has been used over the 2- to 26-Mc band.

PROBLEM STATUS

This report covers a phase of problem R09-32R related to the development of high-frequency Common Antenna Working systems. Work is continuing on this problem.

AUTHORIZATION

NRL Problem R09-32R

NE 021-019

A REFLECTOMETER FOR H-F BAND

INTRODUCTION

The work with which this report is concerned is part of a program directed toward improving the efficiency of shipboard communication antennas in the high-frequency band (2- to 18-Mc) by developing Common Antenna Working systems (CAW) and broad-band antennas, so that several transmitters or receivers can be operating simultaneously on a common antenna. A simple device for indicating a match to a transmission line is a necessary component for the Common Antenna Working system. The reflectometer described in this report meets this requirement.

Devices have been designed for measuring the direct and reflected waves independently on transmission lines and wave guides at the ultra-high and microwave frequencies. Such devices are generally called reflectometers or directional – couplers. Some of these reflectometers operate on the principle that, if the voltages induced in the reflectometer circuit by capacitive and inductive coupling to the transmission line can be made equal and opposite for one wave, e.g., the direct wave, then these voltages will be in phase for the reflected wave. Hence, under this condition the reflectometer is capable of measuring the magnitude of the reflected wave.

These general principles have been extended to the lower frequencies. Reflectometers have been developed which operate in the high-frequency band and some of them have been used over a frequency range greater than ten to one without adjustment. The circuit arrangement is such that the voltage in the reflectometer circuit, due to the inductive coupling for the direct wave, has a phase angle of 180° relative to the inductively coupled voltage for the reflected wave. On the other hand, the sign of the capacitively couple voltage in the reflectometer circuit is the same for both the direct and the reflected waves. Thus the inductively coupled voltage can be either in phase or out of phase with respect to the capacitive-coupled voltage. If the circuit parameters of the reflectometer circuit are adjusted so that the capacitively and inductively coupled voltages are equal and opposite for the direct waves, then the device will measure the reflected wave in the transmission line. The magnitude of the direct wave can be measured by simply reversing the transmission-line connections to the reflectometer.

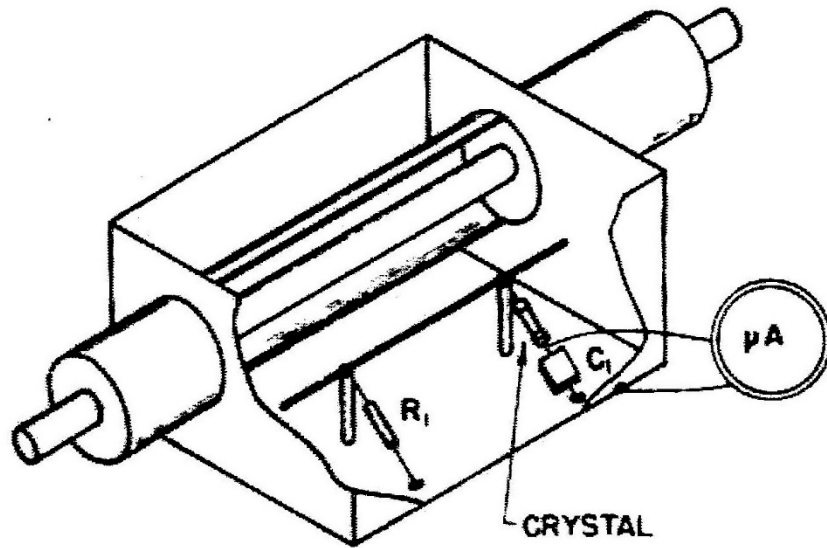

Figure 1.

THEORY

The reflectometer circuit is shown pictorially in Figure 1. The coupling wire is inductively and capacitively coupled to both the inner and outer conductors (shielded box) of the transmission line. Since the length of this wire is very small compared to the wave length, lumped constant can be used for the inductive and capacitive-coupling impedances as well as the inductance of the wire. The capacitive and inductive coupling to the outer conductor are omitted from Figure 2. The coupling wire is very close to the inner conductor so the capacitive and inductive coupling to the inner conductor is much greater than it is to the outer conductor. The capacitive coupling of high impedance is in parallel with the resistances, R_1 and R_2 , which are

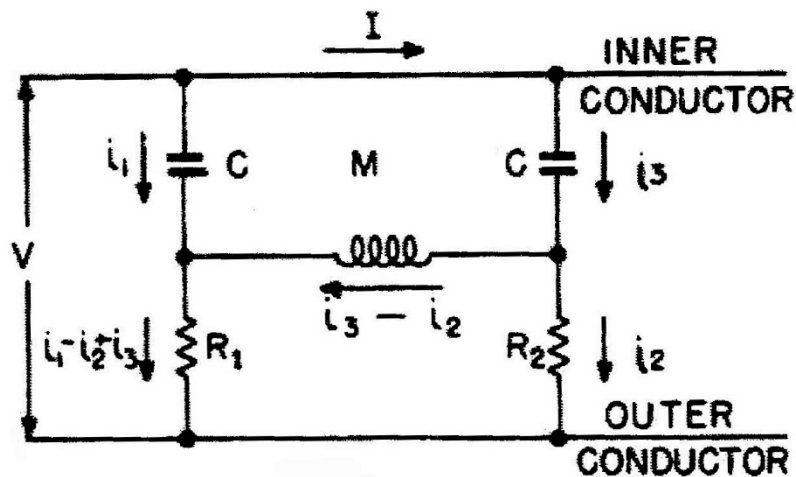

Figure 2.

of the order of 100 ohms; hence, this capacitive coupling can be neglected. Since one cannot compute the inductive-coupling impedances to either the inner or outer conductors accurately, and since the effect of the inductive coupling to the outer conductor is equivalent to reducing the inductive coupling to the inner conductor, the inductive coupling impedance to the outer conductors can be neglected in the approximate solution. The detector circuit of Figure 1 has been replaced by a resistance R_2 , in Figure 2. This approximation is justified in the analysis. Thus the simplified equivalent circuit of Figure 2 is justified and is sufficiently accurate for determining an approximate solution and general design information.

The problem is to determine the equations involving R_1 , L , C , and frequency that must be satisfied in order that the current through the detector of resistance, R_2 , is zero when there is only a direct wave on the transmission line. The boundary conditions that must be satisfied in Figure 2 are

$$V = IZ_0 \quad (1)$$

$$\text{and } i_2 = 0 \quad (2)$$

where V is the voltage across the transmission line for a direct wave only on the line. The shift in phase of the voltage, V , over the length of the coupling wire is neglected. The direct wave of current on the transmission line is represented by I and Z_0 is the characteristic impedance of the transmission line.

The following equations must be satisfied in Figure 2.

$$V = \frac{i_1}{j\omega C} - (i_3 - i_2)j\omega L + Ij\omega M + i_2 R_2 \quad (3)$$

$$V = \frac{i_3}{j\omega C} + i_2 R_2 \quad (4)$$

$$(i_1 - i_2 + i_3)R_1 = -(i_3 - i_2)j\omega L + Ij\omega M + i_2 R_2$$

(5)

After eliminating i_1 , i_2 , and V from equations 1, 3, 4, and 5 one has

$$i_2 = \frac{I \left\{ 2Z_0 - Z_0 \omega^2 LC - \frac{M}{R_1 C} - 1 \left[\omega M - \frac{\omega L Z_0}{R_1} \right] \right\}}{\left\{ 2R_2 - R_2 \omega^2 LC + \frac{L}{C R_1} + j \left[\omega L - \frac{1}{\omega C} \right] \left[1 + \frac{R_2}{R_1} \right] \right\}}$$
(6)

If one sets $i_2 = 0$ in accordance with the boundary conditions (equation 2), then one obtains equations 7 and 8 from the real and imaginary parts of equation 6, or:

$$M = R_1 C Z_0 (2 - \omega^2 LC)$$
(7)

And

$$M R_1 = L Z_0$$
(8)

The operating frequency is so far below the resonance frequency that the value of the term $\omega^2 LC$, in equation 7 is negligible in comparison with 2: thus equation 7 is reduced to

$$M = 2 R_1 C Z_0$$
(9)

The circuit parameters L , M , and C are not independent of one another and are a function of the spacing, D , between the coupling wire and the inner conductor, the diameter of the coupling wire, the diameter of the inner conductor, and the length of the coupling wire. Thus R_1 and D can be selected as the independent variables in equation 8 and 9. The approximate values of R_1 , L , M and C meeting the requirements of the above equations should be computed for several physical configurations. The final numerical values of R_1 and the spacing, D , which will satisfy equations 8 and 9, can be found experimentally. For the above values of R_1 and D , the current, i_2 , through the resistance, R_2 , will be zero for a direct wave on the transmission line and the current, i_2 , will be a measure of the reflected wave on the transmission line.

It should be noted that equations 8 and 9 are independent of the frequency and R_2 . Thus if the circuit parameters are adjusted to satisfy equations 8 and 9 at frequencies f_1 and f_2 , then these equations should be fulfilled for all frequencies between f_1 and f_2 . The theoretical bandwidth over which the reflectometer can be used is limited by the approximation made in obtaining the equivalent circuit as well as the neglect of terms containing $\omega^2 LC$.

The reflectometer must be sufficiently sensitive for practical applications, that is, the current, i_2 must be of such magnitude as to be accurately measured when the device is connected for measuring the direct wave. The ratio, i_2/I , is a measure of the sensitivity.

If the parameters of the reflectometer (L , M , C , and R_1) are adjusted for $i_2 = 0$ for direct wave on the line, then the current, i_2 , is a measure of the reflected wave. For the reflected wave of current I , the signs of the $j\omega M I$ terms are changed in equations 3 and 5 and this corresponds to changing the sign of the terms containing M in equation 6. After changing the sign of all terms containing M and neglecting all terms containing, $\omega^2 LC$ ($\omega^2 LC \ll 1$), one has

$$i_2 = \frac{I \left\{ 2Z_0 + \frac{M}{R_1 C} + \left[j\omega M + \frac{\omega L Z_0}{R_1} \right] \right\}}{2R_2 + \frac{L}{C R_1} - j \frac{1}{\omega C} \left[1 + \frac{R_2}{R_1} \right]} \quad (10)$$

Substituting equation 8 and 9 in equation 10 and solving for the magnitude of i_2/I , one obtains;

$$\left| \frac{i_2}{I} \right| = \left(\frac{Z_0}{R_1 + R_2} \sqrt{\frac{4 + \left(\frac{\omega^2 L^2}{R_1^2} \right)}{\frac{R_1^2}{\omega^2 L^2} + 1}} \right) \quad (11)$$

Since $\omega L/R_1 \ll 1$ in the practical circuits, the series-expansion method was applied to equation 11 to obtain the following approximate solution:

$$\left| \frac{i_2}{I} \right| \cong \frac{2\omega LZ_0}{R_1(R_1 + R_2)} \quad (12)$$

It is general practice to use a crystal rectifier and a d-c microammeter to measure small r-f currents and voltages. In the circuit under consideration, the ratio of i/i_2 (where i is the rectified d-c current corresponding to a r-f current, i_2) will be less than 0.45. For an efficient half-wave rectifier, this ratio will not be appreciably less than 0.45. Thus the sensitivity is given to a fair approximation by;

$$\frac{i}{I} = \frac{0.45 \omega LZ_0}{R_1(R_1 + R_2)} \quad (13)$$

One observes in equation 13 that the sensitivity is proportional to the frequency. On the other hand, the circuit parameters must satisfy equations 8 and 9 and these equations are not a function of R_2 as is the sensitivity equation. Thus the sensitivity of the reflectometer can be controlled by varying R_2 without affecting its operation.

REFLECTOMETER DESIGN

The most important factor in the design of a reflectometer is to have sufficient mutual inductance, M , so that the requirements of equation 8 and 9 can be fulfilled, and at the same time to have sufficient sensitivity. The reflectometer shown in Figure 1 was designed for the frequency range of 4- to 15-Mc. Approximate values of M , L , and C were calculated for several lengths of coupling wire as well as several spacings from the inner conductor. The shortest length of coupling wire that would meet the design requirements was used in the experimental measurements to determine the design constants accurately. The spacing, D , and the resistance, R_1 , were chosen as the independent variables and were adjusted until $i_2 = 0$ at frequencies of 5 and 15 Mc for a direct wave on the transmission line. This reflectometer was found to operate satisfactorily over the frequency band of 2- to 26-Mc. No measurements were made to determine the maximum frequency range over which it could be used.

The circuit parameters are given in terms of nomenclature shown in Figure 1. The resistance, R_1 , is 80 ohms and the rectifier is a Type 1N34 crystal. The spacing, D , and the length of the coupling wire are 1.25 and 4.5 inches respectively. In this particular design the final balance of the reflectometer circuit was obtained by varying the position of the resistance, R_1 , along the coupling wire. The length of coupling wire between R_1 and the rectifier is 2.25 inches. The shielded box which acts as the outer conductor is 7 inches long, 4 inches wide, and 2.5 inches high. The sensitivity of this instrument, i/I , is 10^{-4} at 15 Mc. For a 100-watt transmitter feeding a 50 ohm transmission line with a matched load, the d-c current, i , would be about 40 and 150 microamperes at 5 and 15 Mc respectively.

APPLICATION

These reflectometers have been employed as a tuning indicators on experimental Common Antenna Working systems operating in the frequency ranges of 2- to 6-Mc, 5- to 15-Mc, and 10- to 26-Mc. A reflectometer is connected in every transmission line between the transmitter and the CAW system in such a way as to read the magnitude of the reflected wave. The operator adjusts the two controls of the CAW system for zero reflected wave or a zero reading on the d-c microammeter. The standing wave ratio on the transmission line between the CAW system and the transmitter is always better than 0.85. Hence, this device meets the requirements as a tuning indicator for the CAW system in the high-frequency band.

ⁱ This is a retyping of the Naval Research Laboratory Report 3538. The original copy which was purchased from the National Technical Information Service, NTIS, had been photocopied serially so many times that it was difficult to read. This retyping is to allow the document to be read while focusing on the content not on interpreting the characters. This is an Unclassified Document as of 2/16/50.